

ST. TAMMANY PARISH COUNCIL

ORDINANCE

ORDINANCE CALENDAR NO: 5832

ORDINANCE COUNCIL SERIES NO: \_\_\_\_\_

COUNCIL SPONSOR: MR. SMITH

PROVIDED BY: COUNCIL OFFICE

INTRODUCED BY: \_\_\_\_\_

SECONDED BY: \_\_\_\_\_

ON THE 13 DAY OF JULY , 2017

AN ORDINANCE ESTABLISHING A NO THRU TRUCKS ZONE  
ON ST. TAMMANY AVENUE (9-I-8) WARD 9, DISTRICT 14)

WHEREAS, St. Tammany Parish Government is charged with protecting the safety and general welfare of citizens of the Parish; and

WHEREAS, St. Tammany Parish has experienced an increase in truck traffic on St. Tammany Avenue leading to a residential neighborhood; and

WHEREAS, the affected citizens have requested a no thru truck zone to remedy the situation.

THE PARISH OF ST. TAMMANY HEREBY ORDAINS: that

SECTION I: A "NO THRU TRUCKS" zone is hereby established on St. Tammany Avenue (9-I-8) as indicated on the attached traffic plan by the Department of Engineering.

SECTION II: The Parish Department of Public Works is directed to post the appropriate signs at these locations.

REPEAL: All ordinances or parts of Ordinances in conflict herewith are hereby repealed.

SEVERABILITY: If any provision of this Ordinance shall be held to be invalid, such invalidity shall not affect other provisions herein which can be given effect without the invalid provision and to this end the provisions of this Ordinance are hereby declared to be severable.

EFFECTIVE DATE: This Ordinance shall become effective fifteen (15) days after adoption.

MOVED FOR ADOPTION BY: \_\_\_\_\_ SECONDED BY: \_\_\_\_\_

WHEREUPON THIS ORDINANCE WAS SUBMITTED TO A VOTE AND RESULTED IN THE FOLLOWING:

YEAS: \_\_\_\_\_

NAYS: \_\_\_\_\_

ABSTAIN: \_\_\_\_\_

ABSENT: \_\_\_\_\_

THIS ORDINANCE WAS DECLARED DULY ADOPTED AT A REGULAR MEETING OF THE PARISH COUNCIL ON THE 3 DAY OF AUGUST , 2017 ; AND BECOMES ORDINANCE

COUNCIL SERIES NO \_\_\_\_\_.

---

STEVE STEFANCIK, COUNCIL CHAIRMAN

ATTEST:

---

THERESA L. FORD, COUNCIL CLERK

---

PATRICIA P. BRISTER, PARISH PRESIDENT

Published Introduction: JUNE 28 , 2017

Published Adoption: \_\_\_\_\_ , 2017

Delivered to Parish President: \_\_\_\_\_ , 2017 at \_\_\_\_\_

Returned to Council Clerk: \_\_\_\_\_ , 2017 at \_\_\_\_\_



**ST. TAMMANY PARISH**  
PATRICIA P. BRISTER  
PARISH PRESIDENT



**Date:** June 5, 2017

**To:** Joey Lobrano  
Right Of Way Coordinator  
Department Of Public Works

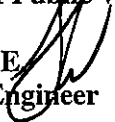
**From:** Jay Watson, P.E.  
Development Engineer 

**Re:** District 14  
Project 17-023  
St. Tammany Ave. 9-I-8  
1-NO THRU TRUCKS sign

The Department of Planning and Development recommends the installation of Signage to be installed in District 14.

1. Install "NO THRU TRUCKS" sign on St. Tammany Ave. 50' from the St. Tammany Ave. and Brownsvillage Rd. intersection.

cc. Councilman Thomas J. Smith  
Theodore C. Reynolds  
Michael Spiehler



St Tammany Ave

St Tammany Ave

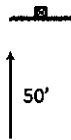

1.

Install "NO THRU TRUCKS" sign

Brownsvillage Rd

Brow

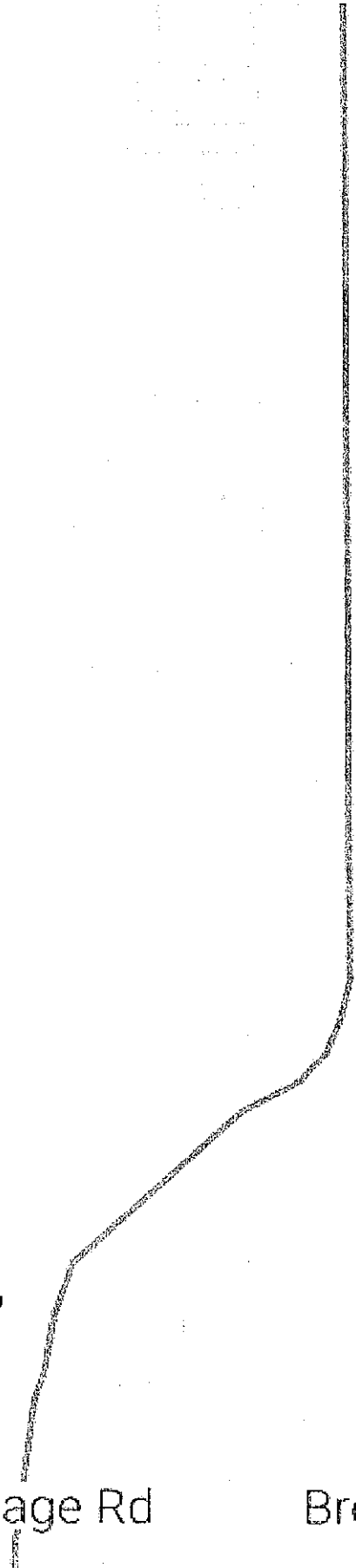

**Figure 2A-2. Examples of Heights and Lateral Locations of Sign Installations**

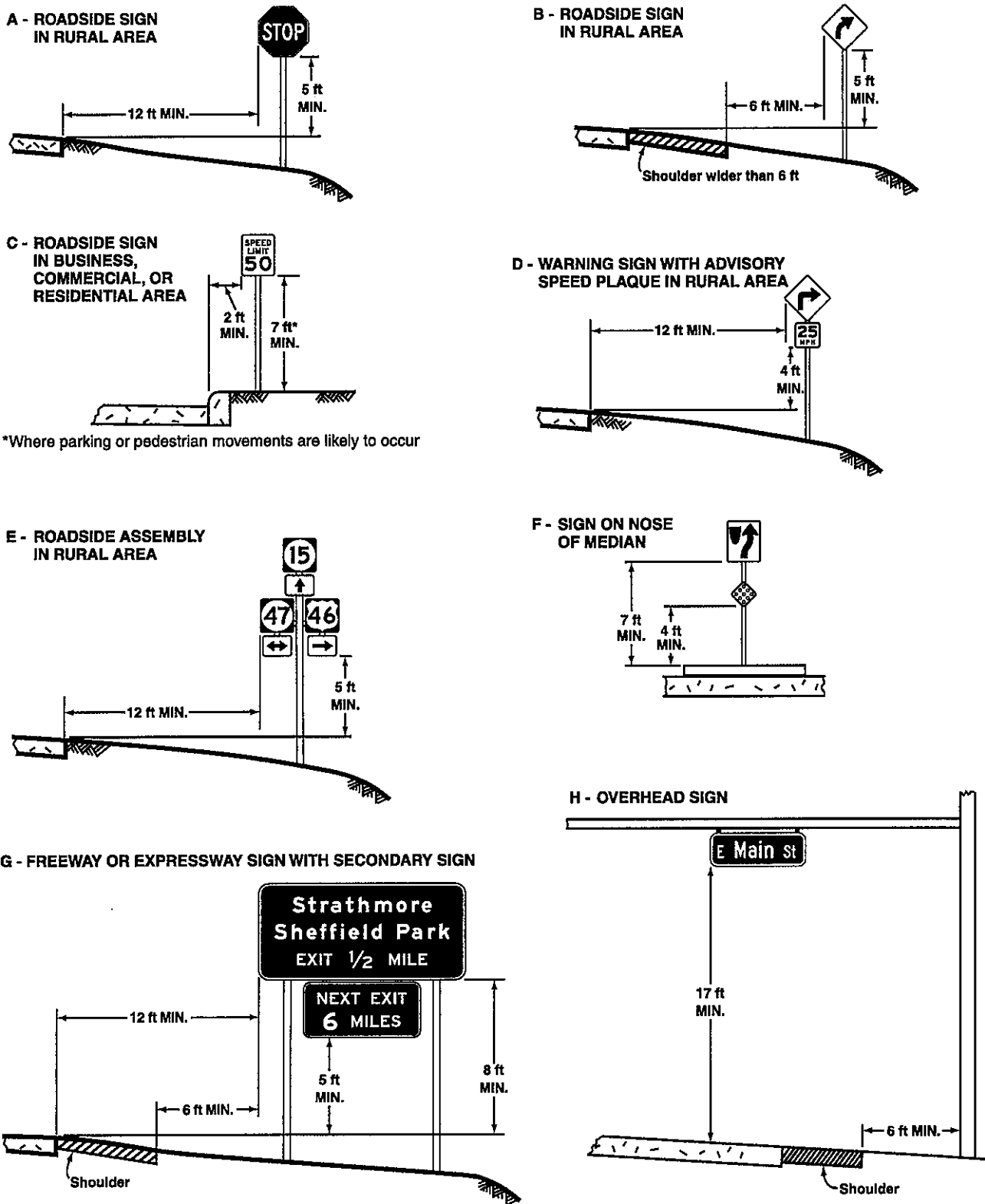

\*Where parking or pedestrian movements are likely to occur

Note:  
See Section 2A.19 for reduced lateral offset distances that may be used in areas where lateral offsets are limited, and in business, commercial, or residential areas where sidewalk width is limited or where existing poles are close to the curb.

**Figure 2A-3. Examples of Locations for Some Typical Signs at Intersections**

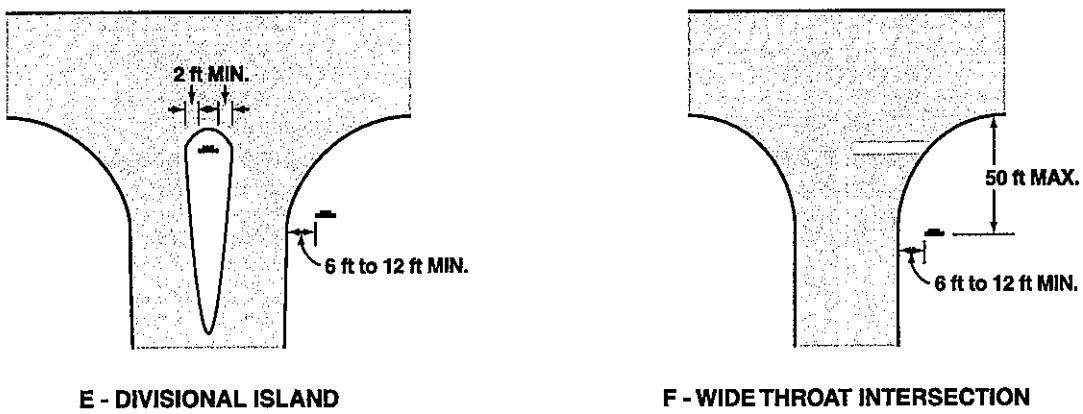
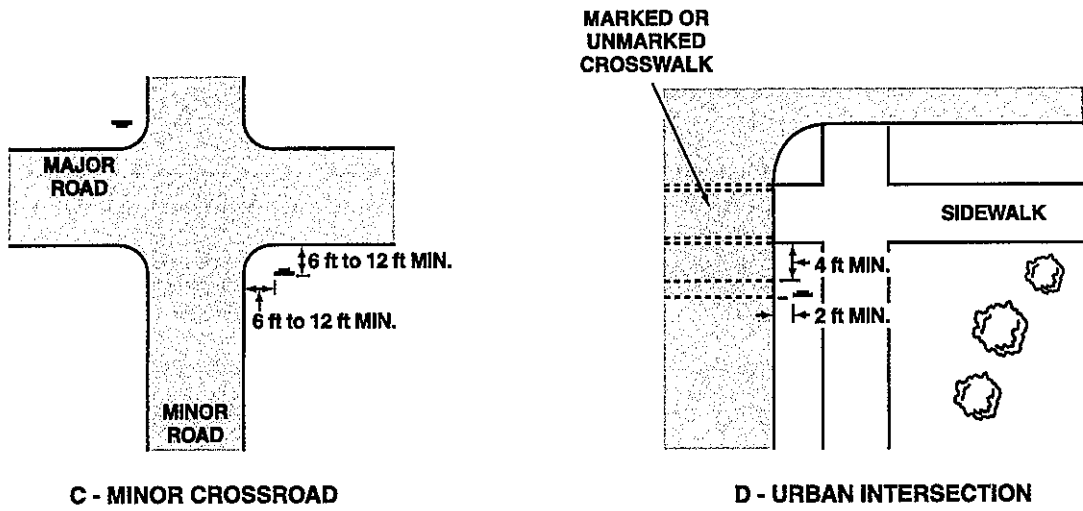
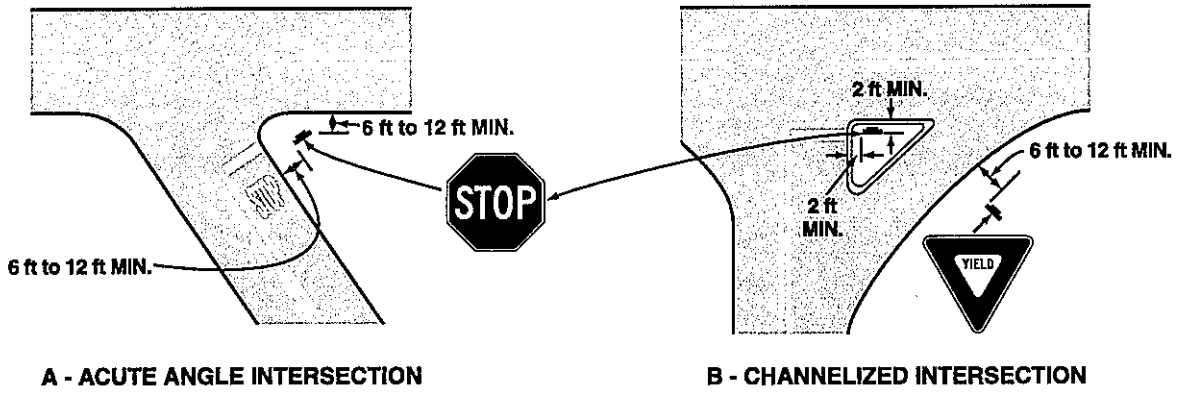

Note: Lateral offset is a minimum of 6 feet measured from the edge of the shoulder, or 12 feet measured from the edge of the traveled way. See Section 2A.19 for lower minimums that may be used in urban areas, or where lateral offset space is limited.