

ST. TAMMANY PARISH COUNCIL

ORDINANCE

ORDINANCE CALENDAR NO: 5760

ORDINANCE COUNCIL SERIES NO: _____

COUNCIL SPONSOR: MR. SHARP

PROVIDED BY: COUNCIL OFFICE

INTRODUCED BY: MR. BELLISARIO

SECONDED BY: MR. BINDER

ON THE 2 DAY OF FEBRUARY , 2017

AN ORDINANCE ESTABLISHING A NO 18 WHEELERS ALLOWED ZONE ON NURSERY ST. (3-J-37) (WARD 3, DISTRICT 2)

WHEREAS, St. Tammany Parish Government is charged with protecting the safety and general welfare of citizens of the parish; and

WHEREAS, St. Tammany Parish has experienced an increase in truck traffic, proceeding at unsafe speeds through primarily residential neighborhoods; and

WHEREAS, the affected citizens have requested a No 18 Wheelers Allowed Zone to remedy the situation.

THE SECTION I: A NO 18 WHEELERS ALLOWED ZONE is hereby established on Nursery St. (3-J-37), WARD 3, DISTRICT 2 as indicated on the attached traffic plan by the Department of Engineering. (WARD 3) (DISTRICT 2)

SECTION II: The Parish Department of Public Works is directed to post the appropriate signs at these locations.

REPEAL: All ordinances or parts of Ordinances in conflict herewith are hereby repealed.

SEVERABILITY: If any provision of this Ordinance shall be held to be invalid, such invalidity shall not affect other provisions herein which can be given effect without the invalid provision and to this end the provisions of this Ordinance are hereby declared to be severable.

EFFECTIVE DATE: This Ordinance shall become effective fifteen (15) days after adoption.

MOVED FOR ADOPTION BY: _____ SECONDED BY: _____

WHEREUPON THIS ORDINANCE WAS SUBMITTED TO A VOTE AND RESULTED IN THE FOLLOWING:

YEAS: _____

NAYS: _____

ABSTAIN: _____

ABSENT: _____

THIS ORDINANCE WAS DECLARED DULY ADOPTED AT A REGULAR MEETING OF THE PARISH COUNCIL ON THE 2 DAY OF MARCH , 2017 ; AND BECOMES ORDINANCE COUNCIL SERIES NO _____.

STEVE STEFANCIK, COUNCIL CHAIRMAN

ATTEST:

THERESA L. FORD, COUNCIL CLERK

PATRICIA P. BRISTER, PARISH PRESIDENT

Published Introduction: JANUARY 26 , 2017

Published Adoption: _____, 2017

Delivered to Parish President: _____, 2017 at _____

Returned to Council Clerk: _____, 2017 at _____



ST. TAMMANY PARISH

PATRICIA P. BRISTER
PARISH PRESIDENT

Date: January 5, 2017

To: Joey Lobrano
Right Of Way Coordinator
Department Of Public Works

From: Jay Watson, P.E. 
Development Engineer

Re: District 2
Project 17-011
Nursery St. 3-J-37
1-"NO 18 WHEELERS ALLOWED" Sign (See attached for reference)

The Department of Planning and Development recommends the installation of Signage to be installed in District 2.

The "No 18 Wheelers Allowed" Sign should be placed as closed to Highway 36 within St. Tammany Parish Right-of-Way in order to be seen from Highway 36.

1. Install a "NO 18 WHEELERS ALLOWED" sign at the intersection of Highway 36 and Nursery Street on Nursery Street with the sign facing South in order to be seen from Highway 36.

cc. Councilman F. Dennis Sharp
Theodore C. Reynolds
Michael Spiehler

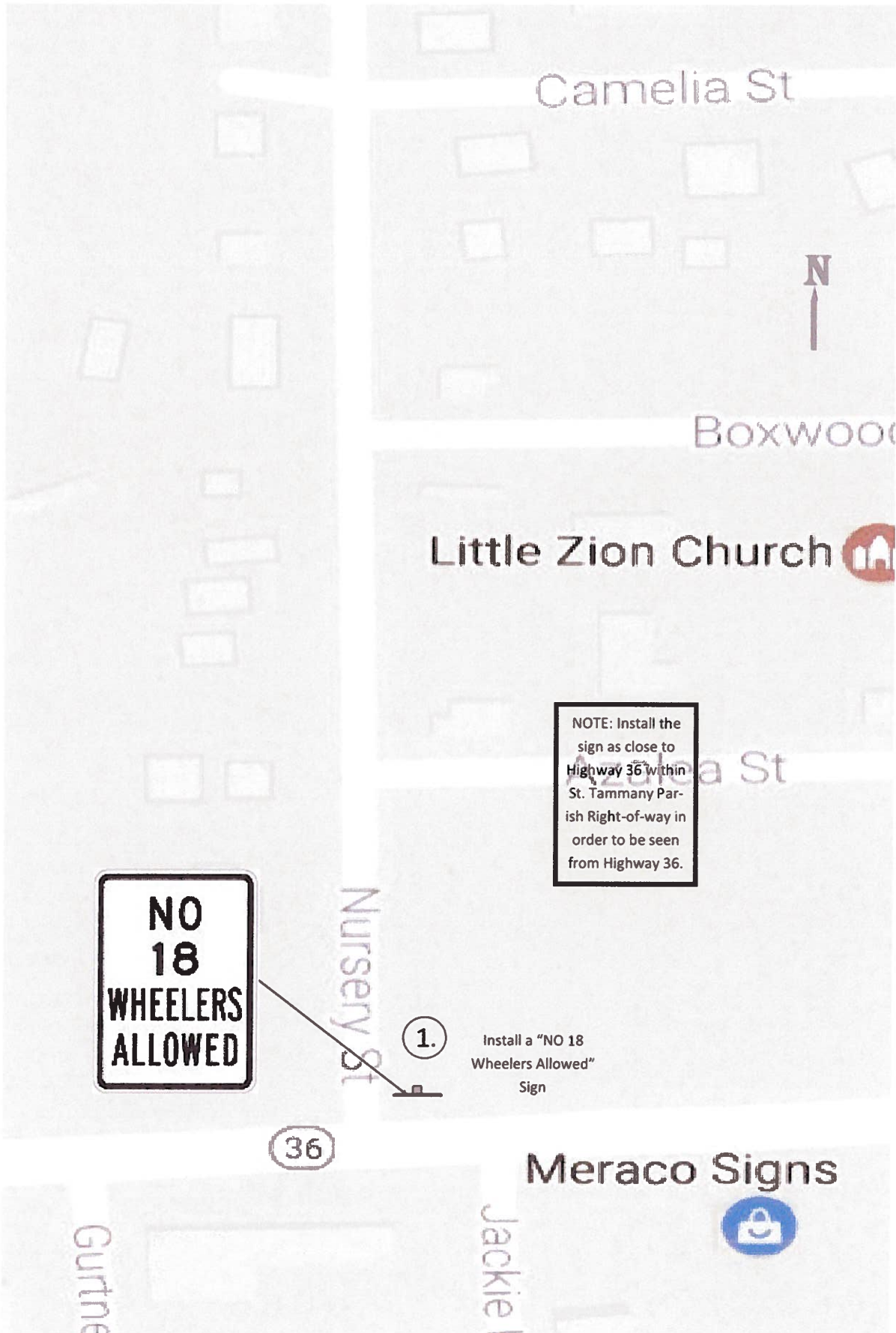

**NO
18
WHEELERS
ALLOWED**

NOTE: Install the sign as close to Highway 36 within St. Tammany Parish Right-of-way in order to be seen from Highway 36.

1.

Install a "NO 18 Wheelers Allowed" Sign

36

Meraco Signs



Figure 2A-2. Examples of Heights and Lateral Locations of Sign Installations

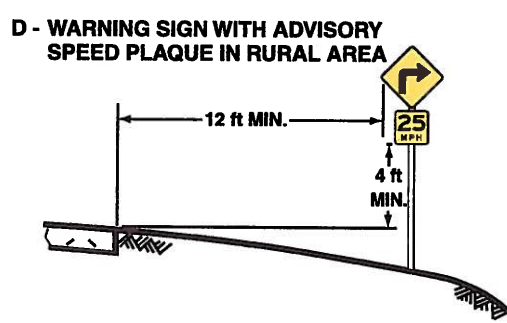
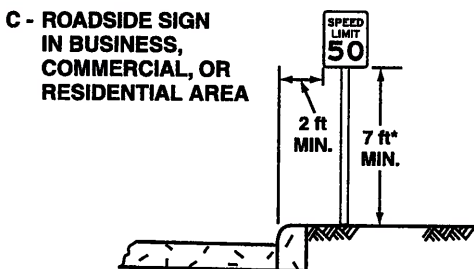
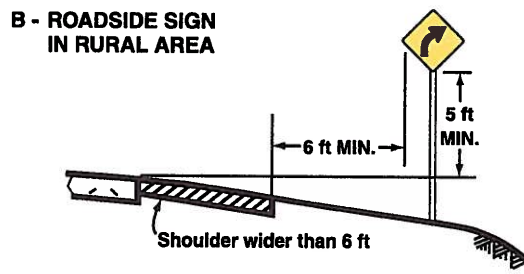
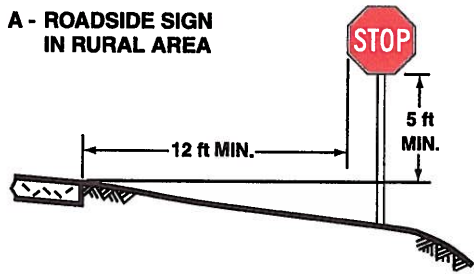

*Where parking or pedestrian movements are likely to occur

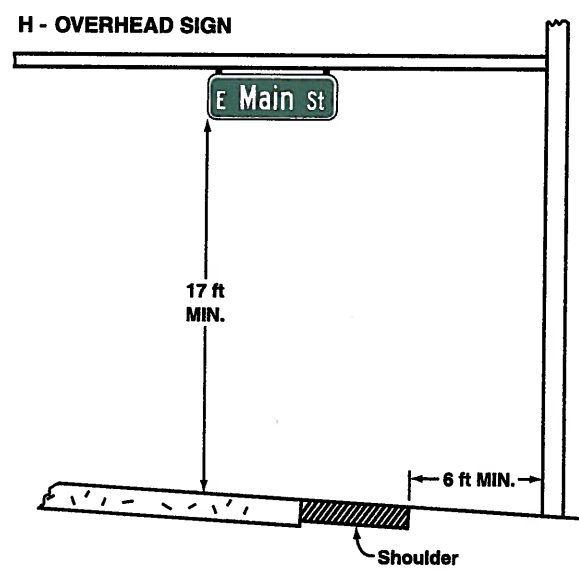
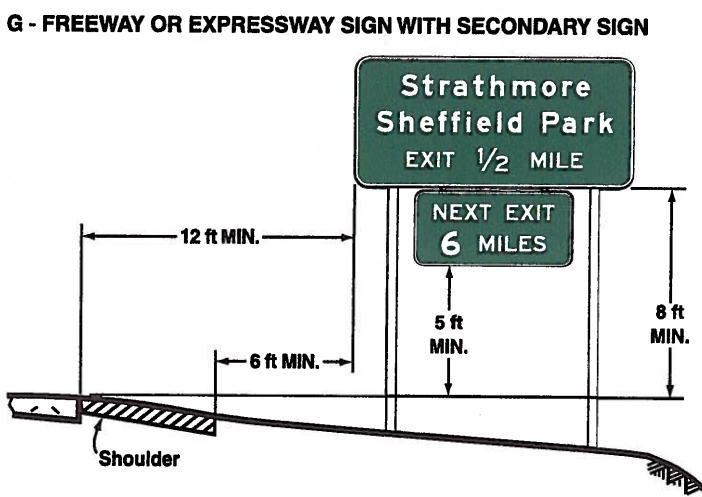
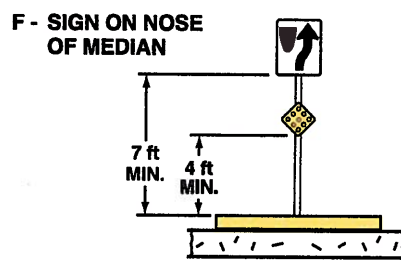
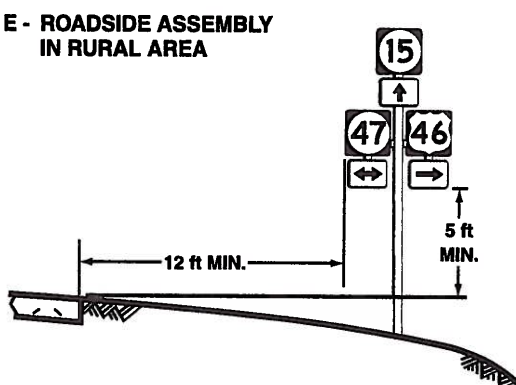

Note:
See Section 2A.19 for reduced lateral offset distances that may be used in areas where lateral offsets are limited, and in business, commercial, or residential areas where sidewalk width is limited or where existing poles are close to the curb.

Figure 2A-3. Examples of Locations for Some Typical Signs at Intersections

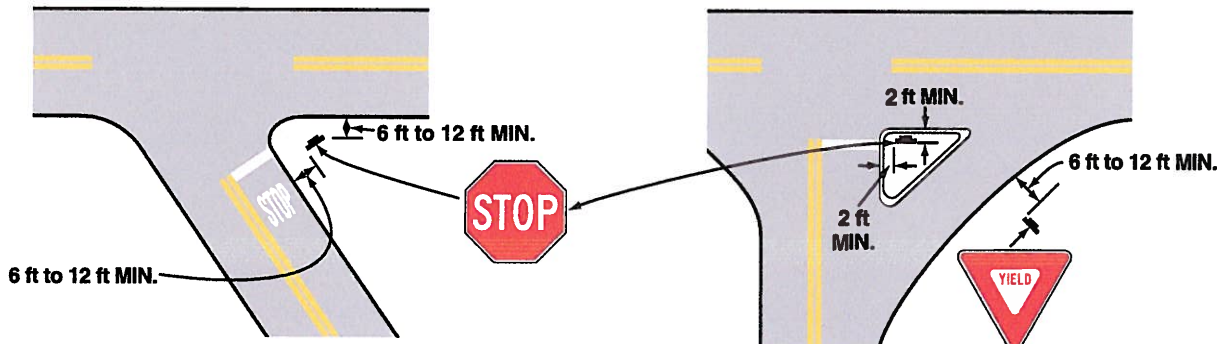

A - ACUTE ANGLE INTERSECTION

B - CHANNELIZED INTERSECTION

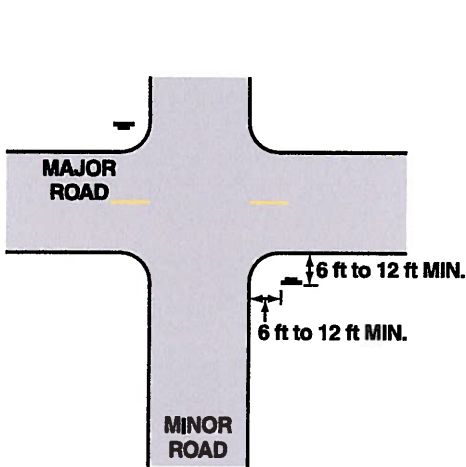

C - MINOR CROSSROAD

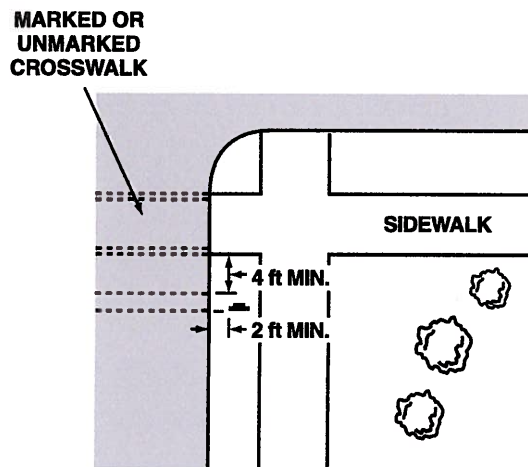

D - URBAN INTERSECTION

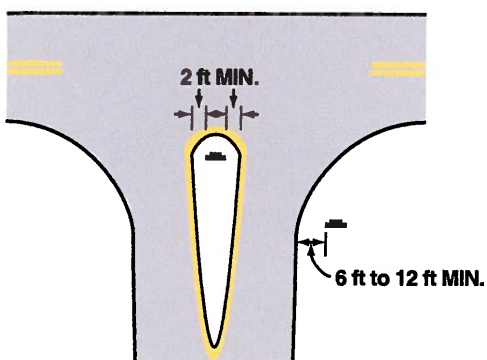

E - DIVISIONAL ISLAND

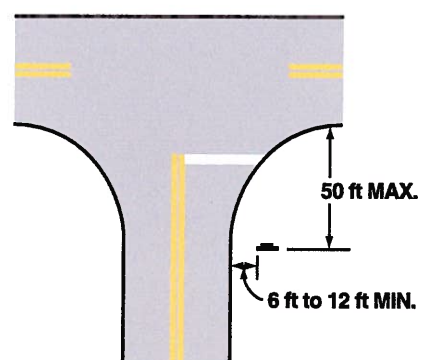

F - WIDE THROAT INTERSECTION

Note: Lateral offset is a minimum of 6 feet measured from the edge of the shoulder, or 12 feet measured from the edge of the traveled way. See Section 2A.19 for lower minimums that may be used in urban areas, or where lateral offset space is limited.